

JB-A12-065

12V65Ah(10hr)



Overview

The rechargeable batteries are lead-lead dioxide systems. The dilute sulfuric acid electrolyte is absorbed by separators and plates and thus immobilized. Should the battery be accidentally overcharged producing hydrogen and oxygen, special oneway valves allow the gases to escape thus avoiding excessive pressure build-up. Otherwise, the battery is completely sealed and is, therefore, maintenance-free, leak proof and usable in any position.

Battery Construction

Component	Positive plate	Negative plate	Container	Cover	Safety valve	Terminal	Separator	Electrolyte
Raw material	Lead dioxide	Lead	ABS	ABS	Rubber	Copper	Fiberglass	Sulfuric acid

General Features

- Positive and negative plates in lead-calcium-tin alloy;
- Stable Quality&High Reliability;
- Sealed Construction;
- Long Service Life;
- Maintenance-Free Operation;
- Low Pressure Venting System;
- Low Self Discharge;
- U.L.Component Recognition;
- Six months shelf life at 20°C;
- Design life 10 years

Battery Specification

Performance Characteristics	
Nominal Voltage	12V
Number of cell	6
Design Life	10 years
Nominal Capacity 77°F(25°C)	
10 hour rate (6.5A, 10.8V)	65.0Ah
5 hour rate (11.3A, 10.5V)	56.5Ah
1 hour rate (44.2A, 9.6V)	44.2Ah
Internal Resistance	
Fully Charged battery 77 °F(25°C)	≤6 .8 mOhms
Self-Discharge	
3% of capacity declined per month at 20°C(average)	
Operating Temperature Range	
Discharge	-20~60°C
Charge	-10~60°C
Storage	-20~60°C
Max. Discharge Current 77°F(25°C)	
	650A(5s)
Short Circuit Current	
	1700A
Charge Methods: Constant Voltage Charge 77°F(25°C)	
Cycle use	2.40-2.45VPC
Maximum charging current	19.5A
Temperature compensation	-30mV/°C
Standby use	2.20-2.30VPC
Temperature compensation	-20mV/°C

Dimensions and Weight

Length(mm / inch)	350/13.78
Width(mm / inch)	167/6.57
Height(mm / inch)	179/7.05
Total Height(mm / inch)	179/7.05
Approx. Weight(Kg / lbs)	23.4/ 51.6

* Weight deviation: 5%

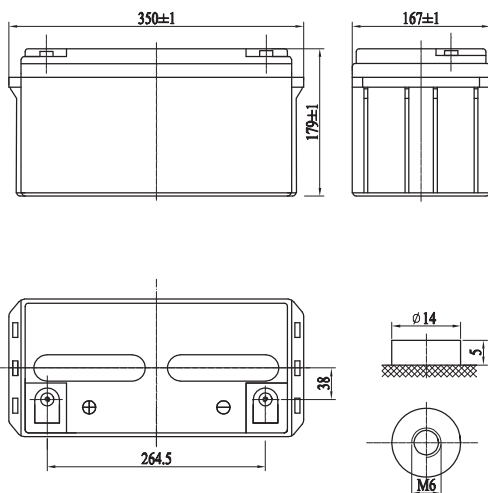

Discharge Constant Current (Amperes at 77°F25°C)

End Point Volts/Cell	Time							
	10min	15min	30min	45min	1h	3h	5h	10h
1.60V	--	125	70.5	53.0	44.2	17.7	12.1	7.01
1.65V	--	116	68.0	52.8	41.9	17.1	11.7	6.90
1.70V	--	114	66.3	50.1	41.5	16.9	11.5	6.76
1.75V	--	108	66.2	49.8	40.9	16.7	11.3	6.61
1.80V	--	100	61.8	47.3	38.3	16.3	11.1	6.50

Discharge Constant Power (Watts at 77°F25 °C)

End Point Volts/Cell	Time							
	10min	15min	30min	45min	1h	2h	3h	5h
1.60V	--	222	132	98.0	80.8	46.1	34.5	22.8
1.65V	--	206	127	96.5	79.0	45.1	33.8	22.6
1.70V	--	197	118	94.5	77.2	44.6	33.7	22.4
1.75V	--	193	116	92.4	75.4	43.2	32.4	22.0
1.80V	--	183	114	91.2	75.0	42.5	31.7	21.7

(Note)The above characteristics data are average values obtained within three charge/discharge cycles not the minimum values.All data shall be changed without notice, We reserves the right to explain and update the information contained hereinto.

JB-A12-065

12V65Ah(10hr)

